

L-65A/4

DN65 1500 r/min

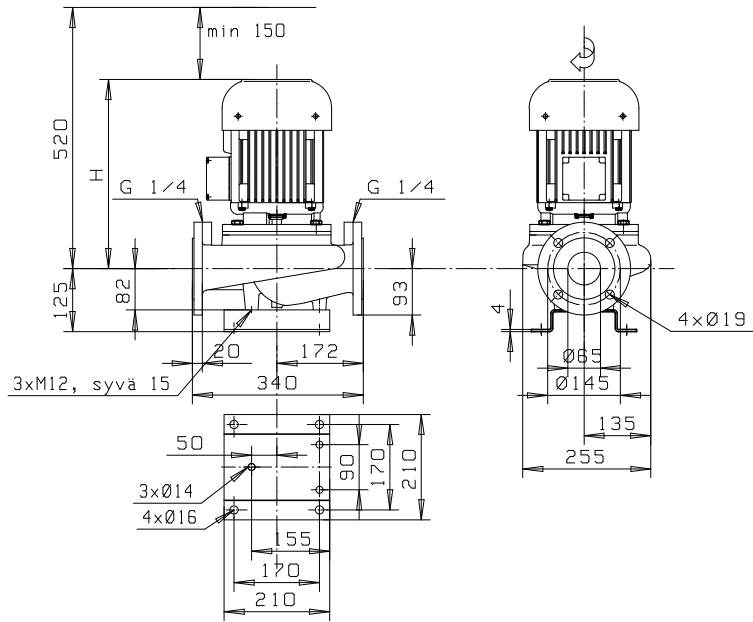

	kW	A	kg	H
OKN-101 D2 F19	1.5	3.5	52	370
OKN-101 D2 P F19 1~	1.5	9.0	52	370
OKN-101 C2 F19	1.1	2.6	48	370
OKN-101 C2 P F19 1~	1.1	6.9	48	370
OKN-100 B2 F19	0.75	2.0	44	320
OKN-100 B2 P F19 1~	0.75	4.7	44	320
OKN-100 B2 F19	0.55	1.4	44	320
OKN-100 B2 P F19 1~	0.55	3.4	44	320
OKN-852 D F19	0.37	1.0	37	310
OKN-852 D P F19 1~	0.37	2.5	37	310
OKN-852 D F19	0.2	0.75	37	310

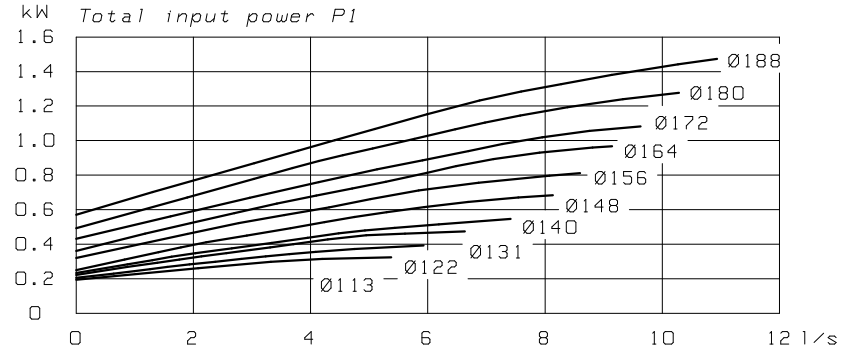
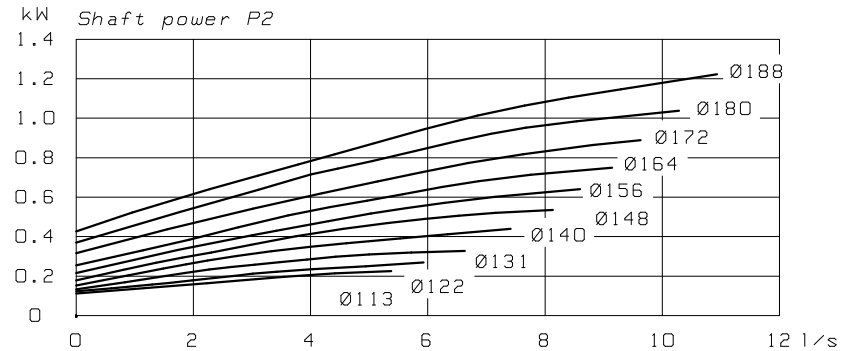
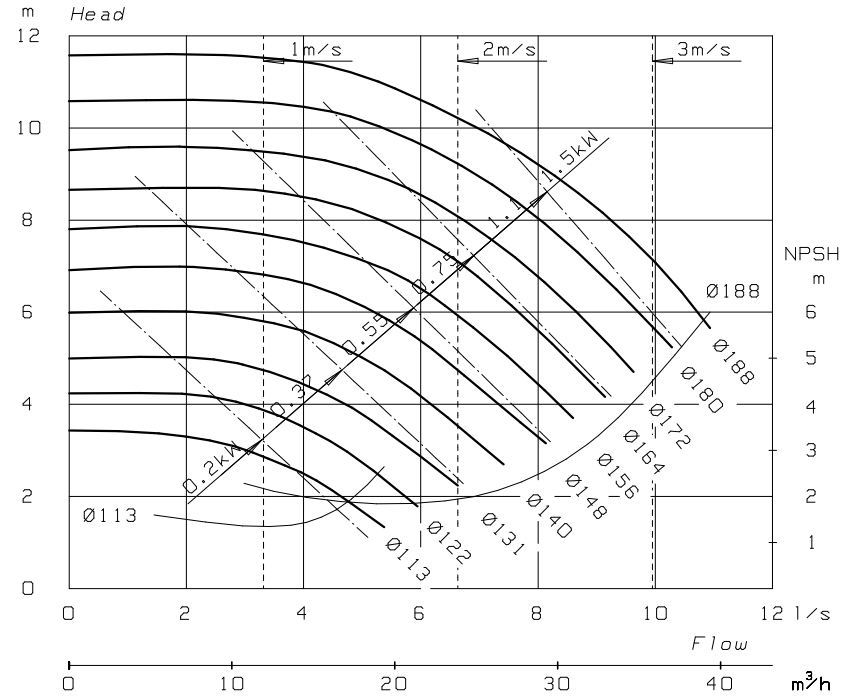
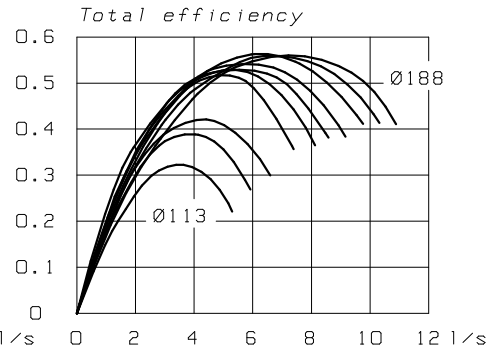
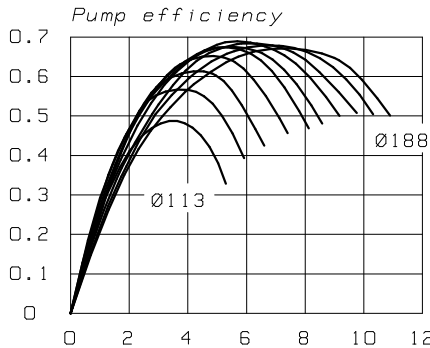

Suunn: 2001-10-29 JS  
 Tark: 2002-01-21 JJT  
 Korvaa: 84393